

Operation: Thimble Structure & Push Lever (顶针式) NANO-SIM卡座

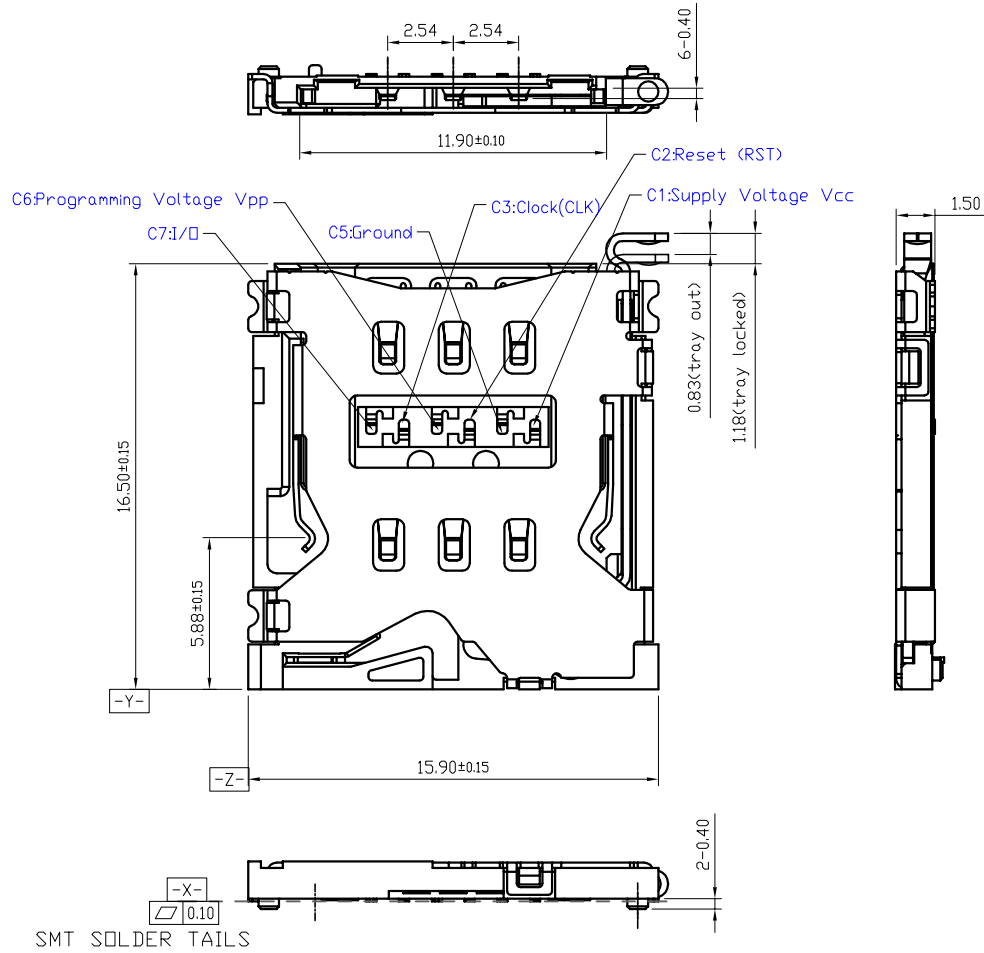

LTEM NO.: SNO-019
(NANO-SIM CARD SOCKETS)

Unit:mm

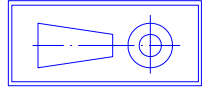

表面貼裝 SMT

側向導入 LATERAL

精密部品 NICETY

可靠 STABILIZE

適合環保 RoHS

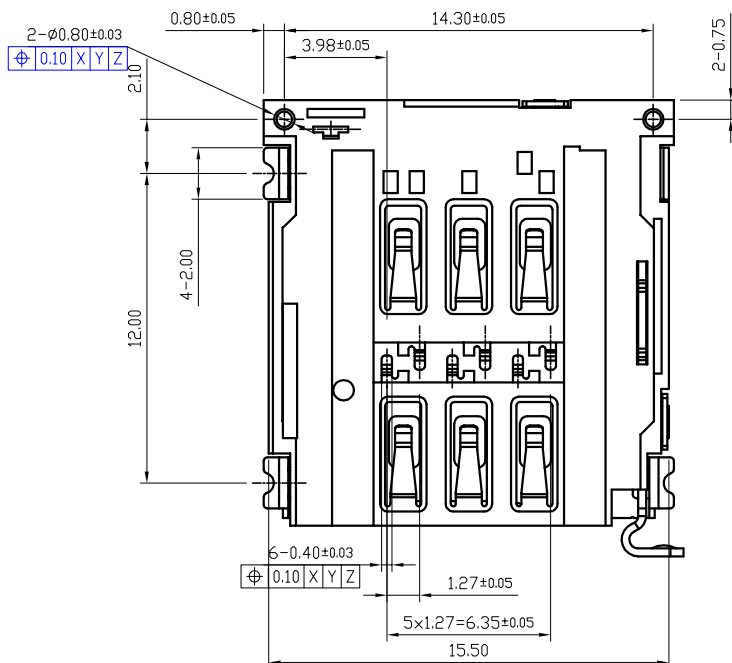

MATED TRAY DIM.
(ONLY FOR STANDARD TRAY)

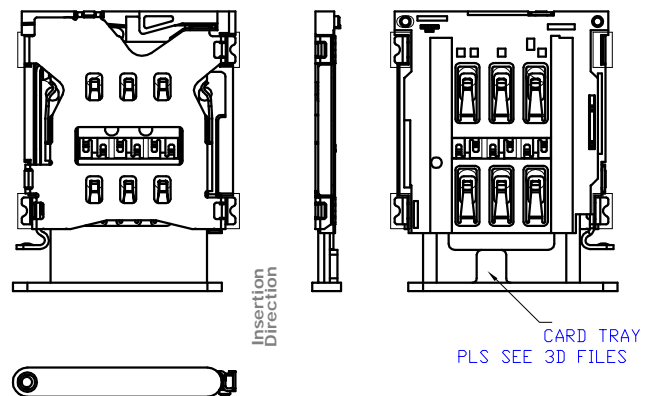

CIRCUIT BOARD SIZE
(Vertical view)

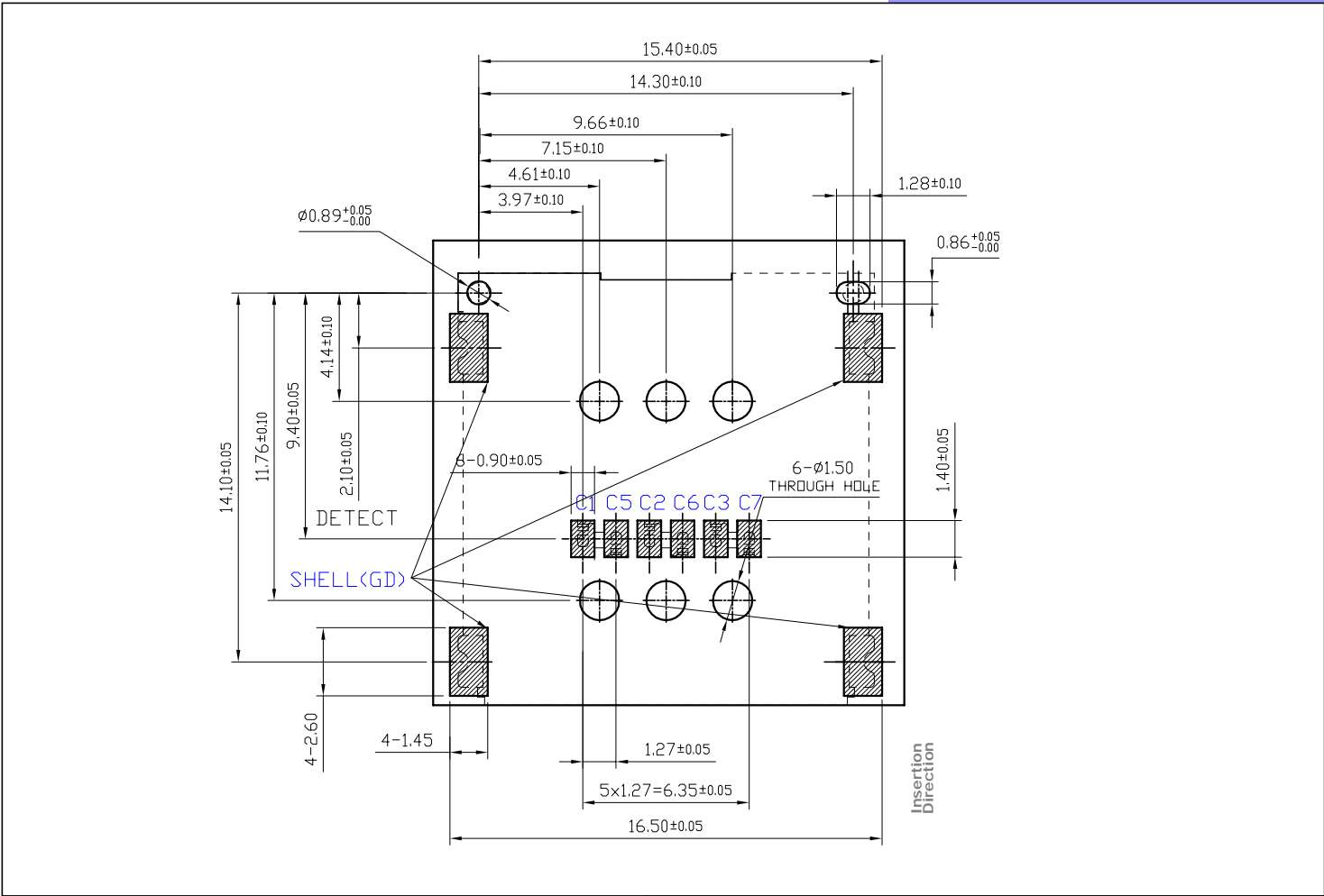

PIN Assignment

SIM CARD Pin DESIGN

Pin No.	Pin NAME	Type	Description
C①	卡電源	1	VCC
C②	復位	1	RST
C③	時鐘	1	CLK
C④	保留項	1	Reserved
C⑤	接地	1	GND
C⑥	Vpp	1	VPP
C⑦	輸入/輸出	1	I/O
C⑧	保留項	1	Reserved

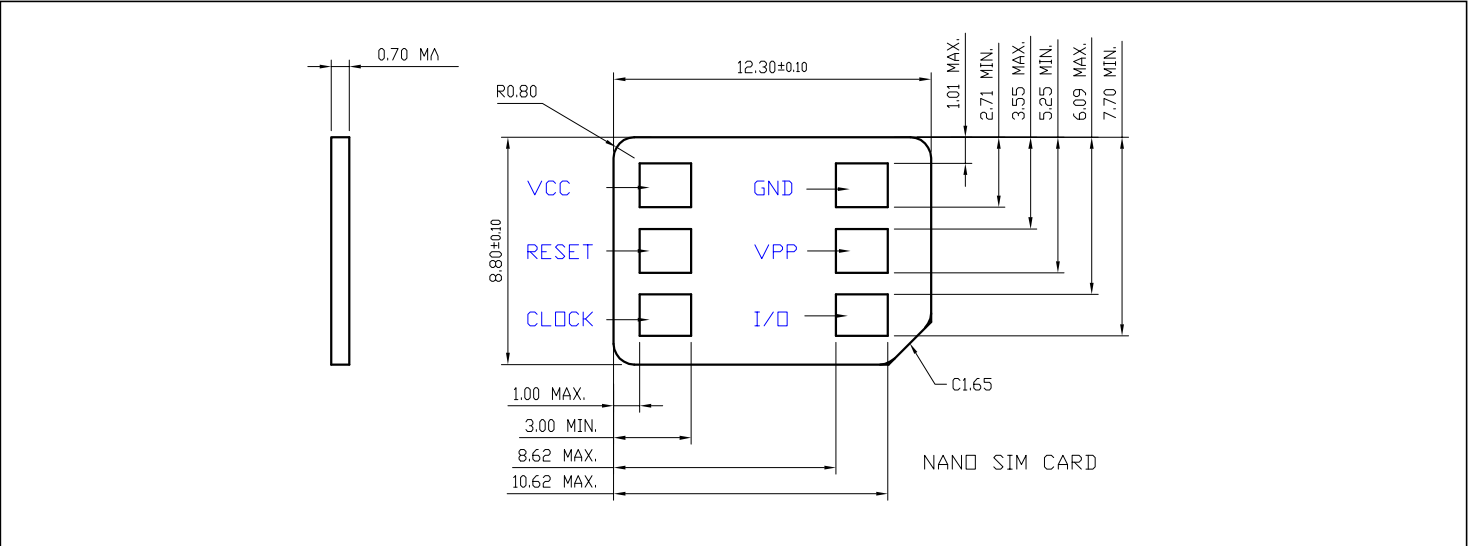

Technical parameter

PROJECT		LEVEL	A [better product]	B [average product]	C [low product]
Electrical Properties	Initial Contact Resistance		30mΩ max.	30mΩ max.	no data!
	Contact Resistance		100MΩ min. 100V DC Skey/PD: 50MΩ min. 100V DC		
	Withstand Voltage		300V AC for 1min	250 V AC for 1min	
Durable Performance	There No Load		8,000 Cycles	7,000 Cycles	no data!
	Rated Load		6,500 Cycles 50mΩ max.	5,000 Cycles 30mΩ max.	no data!
Insertion Force			4.0Kgf MAX (Springback:)		

本品不屬於危害性廢棄物,須丟棄時可以委託回收商予以回收再生處理。Products do not belong to hazardous waste, When waste can recycling processing

運送時本產品不要直接與水、酸鹼性化學物質接觸,或放置於含有以上氣體環境中,並且需要注意會有滑落、側翻的危險發生;運輸過程中不能有碰撞或者擠壓,須保證溫度與濕度適中[常溫 25°C,濕度在 50°C 以內],不可導致材料變形或氧化。

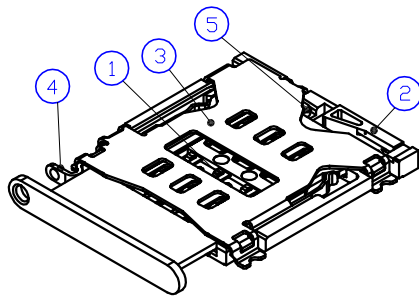

Material declaration			
No.	NAME	MATERIAL	DESCRIPTION
① A	CONTACT	COPPER ALLOY 【G/F】	0.1 μm Ni PLATED OVERALL; BRONZE ALLOY, GOLD PLATING
② B	HOUSING	THERMOPLASTIC	UL 94V-0,COLOR:BLACK;
③ C	SHELL	STAINLESS 【G/F】	SUS304, GOLD PLATING;
④ D	LEVER	STAINLESS 【G/F】	SUS304, NO PLATING;
⑤ E	HINGE	STAINLESS 【G/F】	SUS304, NO PLATING;

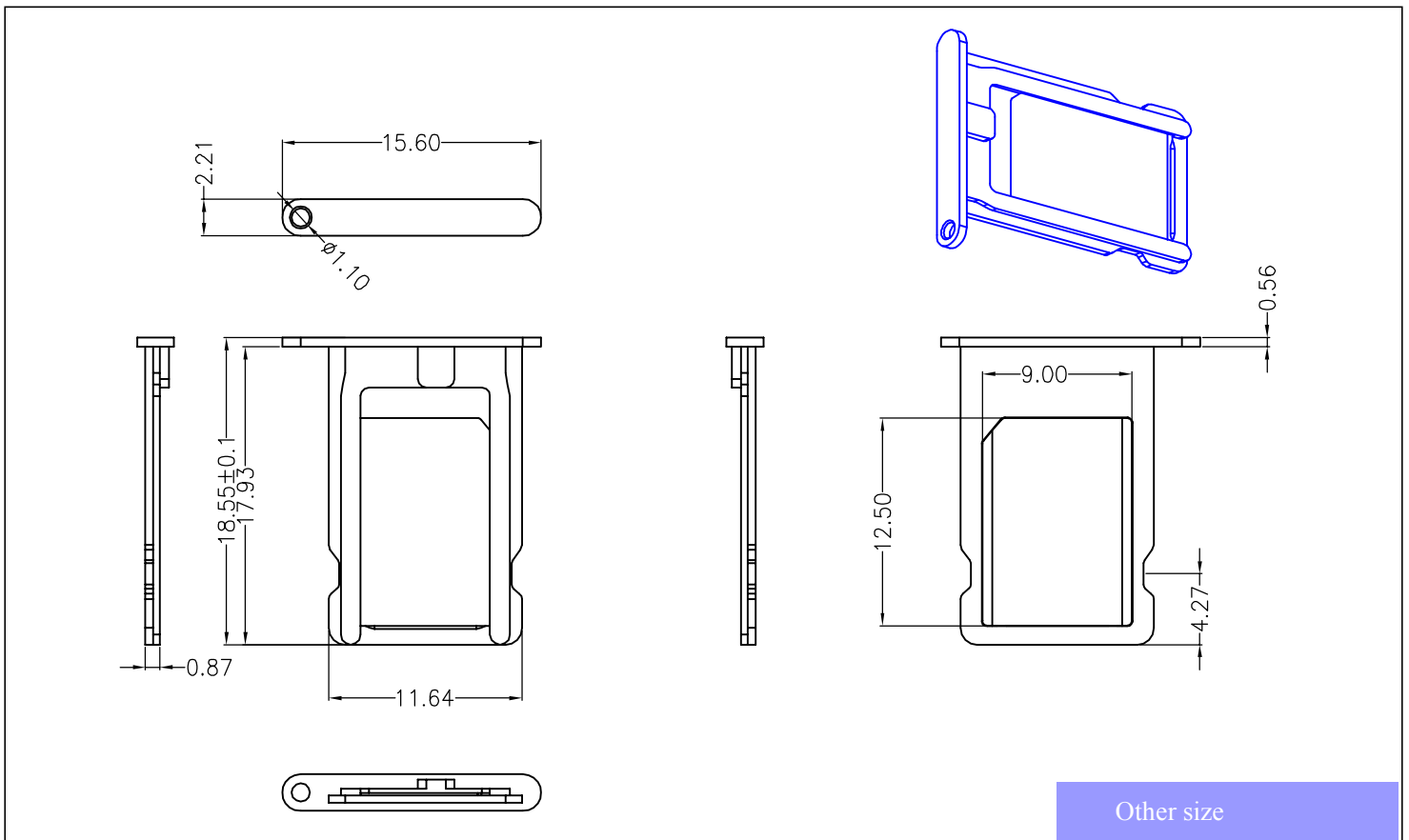

Other size

注記 NOTICE

1. 碩方電子公司擁有最終解釋權; The company reserves the right of final interpretation;
2. 文件禁止外洩、轉載; Leaked and reproduced prohibited;
3. 未經授權修改無效。Modify is invalid.

单击下面可查看定价，库存，交付和生命周期等信息

[>>SOFENG\(硕方\)](#)